

CHANNEL

Q1000CI/Q3300CI CONCRETE INSERT CHANNELS

1 CABLE TRAY/
ACCESSORIES

2 CABLE LADDER/
ACCESSORIES

3 CHANNEL/
ACCESSORIES

4 FASTENERS

Q1000CI/Q3300CI

Length 6M or 3M, Cut to size sections available for firm orders.

Profile 41mm x 41mm and 41mm x 21mm

- 2.5mm Mild Steel Post Production Hot Dip Galvanised to AS/NZS1365, AS1594, AS/NZS4680, ISO1461
- Anchor hooks pressed at 200mm continuous centres
- Removable foam insert

Loading Data

Concrete Insert Channel loading is based on the strength of the concrete used in the installation. Maximum load before pull out failure is 9.3kN per 300mm section when cast in 25Mpa concrete.

Safety Factor: Ultimate load divided by 3

Q1000CI-CONCRETE INSERT

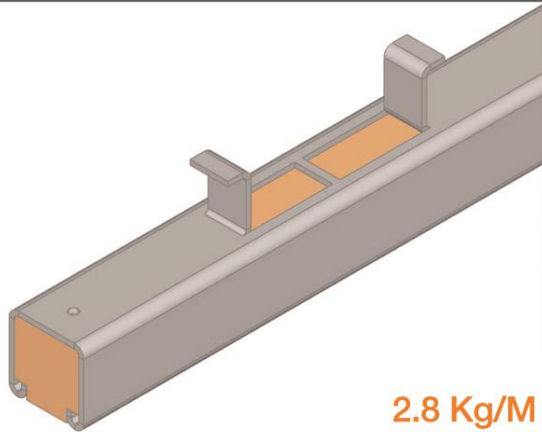

2.8 Kg/M

Q3300CI-CONCRETE INSERT

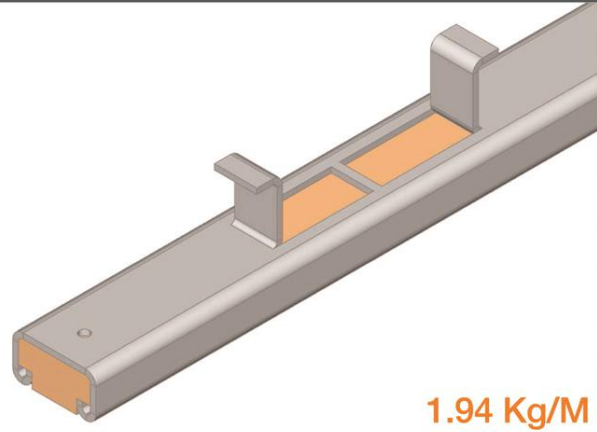

1.94 Kg/M

CONCRETE CHANNEL INSERT ORDERING INFORMATION

① PRODUCT CODE		② FINISH	
Q1000CI	41mm x 41mm x 6M	H	Hot Dip Galv.
Q3300CI	41mm x 21mm x 6M		
Q1000CI-20	41mm x 41mm x 200mm		
Q1000CI-40	41mm x 41mm x 400mm		
Q1000CI-60	41mm x 41mm x 600mm		
Q1000CI-80	41mm x 41mm x 800mm		
Q3300CI-20	41mm x 21mm x 200mm		
Q3300CI-40	41mm x 21mm x 400mm		
Q3300CI-60	41mm x 21mm x 600mm		
Q3300CI-80	41mm x 21mm x 800mm		

EXAMPLE ① ②
Q1000CIH Q1000CIH H